

7175 RVS meskantafsluiter pneumatisch DW

APPLICATION

The knife gate valve is particularly suitable for the most difficult applications.

Area of use: water treatment networks, pulp and paper industry, chemical plants, winemaking, cement works, pneumatic transport, storage.



Fluids: water, sewage, pulp, pasty products, powdery, granular, fibrous, abrasive and crystallizing.

GENERAL CHARACTERISTICS

Range: DN50 to DN1200.

- Knife Gate Valve on/off or regulation with rising stem.
- Molded monobloc body
- Unidirectional water tightness: Flow direction indicated on the body with an arrow.
- Installation between flanges ISO PN10.
- Small retention zone.
- Gate with a beveled cutting edge guided in the body with little backlash.
- Guaranteed closure, without risk of blockage.
- Standard polished gate, soft contact with the gaskets.
- Very resistant stainless steel packing flange avoids risks of breaks.
- Operating force reduced thanks to the elasticity of the gaskets.
- Pre-formed profiled sheet metal support plates from DN50 to DN300 for accessory or kit mounting.
- Full flow when fully opened, ensuring a high flow rate with low head loss.
- Flow regulation possible for pasty or abrasive fluids with installation of a deflector.

STANDARDS

Design	Manufacture according to the requirements of the European directive n° 2014/68/UE «Equipment under pressure» : modulate H.					
	In option: product conform to European directive ATEX «ATmosphère EXplosive» n° 2014/34/UE.					
Face to face	Face to face dimension according to standard					
Connection	Mounting between flanges in accordance with EN1092-2 and ISO 7005-1 : ISO PN10					
Tests	Pressure test according to standards EN12266-1, DIN 3230, BS 5154 and ISO 5208.					
	DN	Body	Seat	DN	Body	Seat
	DN50-250 :	15.4 bar	11 bar	DN300-450:	12.6 bar	7.7 bar
DN500-600:	7.2 bar	4.4 bar	DN700-1200:	3 bar	2.2 bar	

PRODUCT APPROVALS

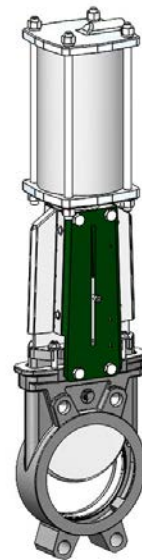

7175 RVS meskantafsluiter pneumatisch DW

CONSTRUCTION

Coatings applied on the valve :

Component	Coating
Support plate (8)	Liquid epoxy RAL 6005 70 microns

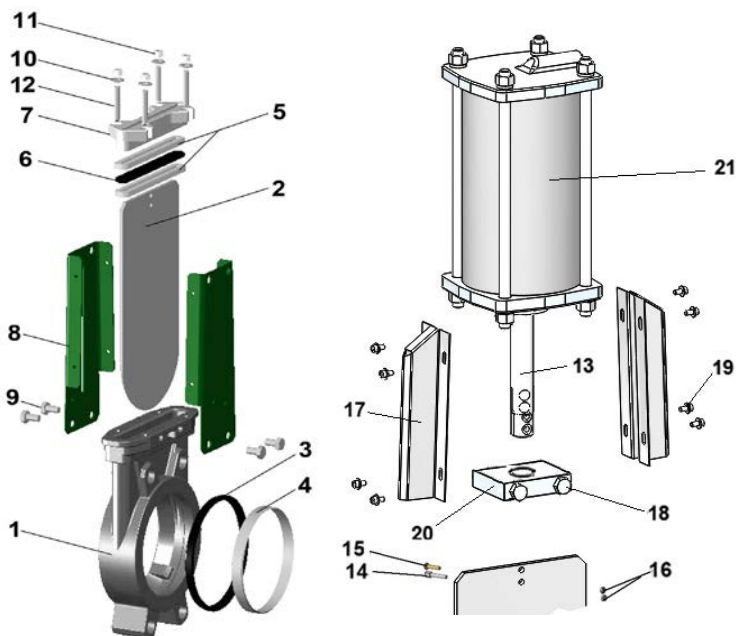

Pos.	Q-ty	Description	Material	Equivalences		
				DIN	ASTM	BS
1	1	Body	Stainless steel GX5CrNiMo 19-11-2	G-X6CrNiMo18 10	A 351 grade CF8M	316 C16
2	1	Gate	Stainless steel X2CrNi 17-12-2	X2CrNiMo17-13-2	A 182 AISI 316L	1449-2 316 S11
3	1	Seat gasket (1)	EPDM			
4	1	Support ring (1)	Stainless steel X5CrNiMo 17-12-2	X5CrNiMo18 10	A 182 AISI 316	1449-2 316 S16
5	2	Packing	PTFE			
6	1	O-Ring	EPDM			
7	1	Packing gland	Stainless steel GX5CrNiMo 19-11-2	G-X6CrNiMo18 10	A 351 grade CF8M	316 C16
8	2	Support plate	Steel			
9	4**	Screw	Stainless steel A2-70			
10	4*	washer	Stainless steel A2-70			
11	4*	Nut	Stainless steel A2-70			
12	4*	Tie rod	Stainless steel A2-70			
13	1	Stem	Stainless steel 13%Cr	X12CR13	AISI 410	
14	1	Detection screw	Stainless steel X5CrNi 18 10	X5CrNi 18 10	A 182 AISI 304	1449-2 304 S15
15	1	Screw	Stainless steel A2-70			
16	2	Nut	Stainless steel X5CrNi 18 10	X5CrNi 18 10	A 182 AISI 304	1449-2 304 S15
17	1	Protection plate	Stainless steel X5CrNi 18 10	X5CrNi 18 10	A 182 AISI 304	1449-2 304 S15
18	4	Screw	Stainless steel A2-70			
19	1	Screw	Stainless steel A2-70			
20	1	Support nut	Zinc plated steel			
21	1	Pneumatic actuator	Aluminium			

* - 8 for DN350-400; ** - 12 for DN450-900 and 16 for DN1000-1200
(1) - Parts missing on valve with metal/metal sealing

The photographs and technical art works are not contractual. The specifications of the presented products are open to modifications without previous advice



7175 RVS meskantafsluiter pneumatisch DW

DIMENSIONS

DN		A	B	C	D	Ø F	Ø P	H	Weight (kg)
mm	inch								
50	2"	40	240	124	83	1/4"	80	412	7,5
65	2 1/2"	40	265	139	83	1/4"	80	458	7.8
80	3"	50	29*0	154	83	1/4"	80	502	8.4
100	4"	50	335	174	83	1/4"	100	562	12.5
125	5"	50	373	189	93	1/4"	125	642	16.4
150	6"	60	424	220	93	1/4"	125	718	20.5
200	8"	60	533	275	108	1/4"	160	882	35.8
250	10"	70	625	326	108	1/4"	200	1044	52
300	12"	70	732	380	108	1/4"	200	1164	72
350	14"	96	835	438	290	3/8"	250	1362	129
400	16"	100	945	494	290	3/8"	250	1542	144
450	18"	106	1040	547	290	3/8"	250	1677	177
500	20"	110	1150	613	290	1/2"	320	1815	268
600	24"	110	1354	716	290	1/2"	320	2130	351
700	28"	110	1540	835	320	1/2"	426	2488	556
800	32"	110	1750	972	320	1/2"	426	2798	679
900	36"	110	1990	1041	320	1/2"	538	3162	840
1000	40"	110	2195	1152	320	1/2"	538	3452	1053
1200	48"	150	2390	1255	400	1/2"	538	4048	-

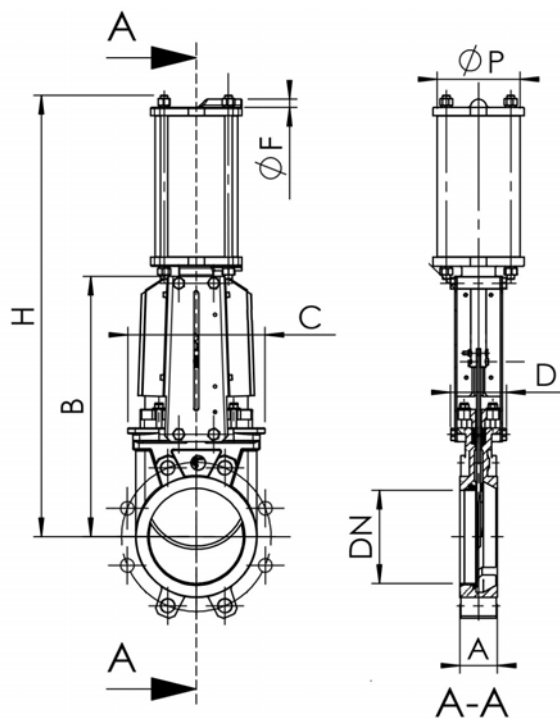

Dimension A - face to face according to standard

MOUNTING

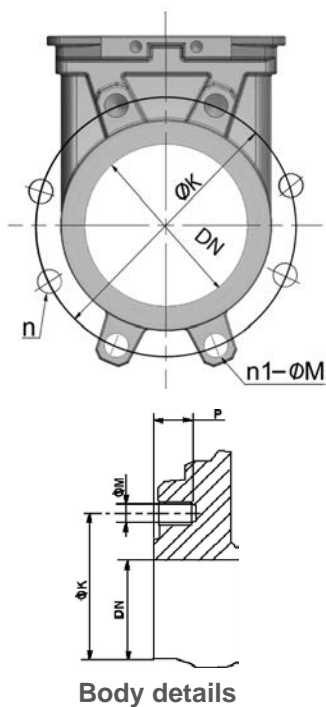

Body details

DN		Maximum pressure (bar)	n	n ₁ -ØM	P	ØK
mm	inch					
50	2"	10	4	4xM16	8	125
65	2 1/2"	10	4	4xM16	8	145
80	3"	10	8	4xM16	9	160
100	4"	10	8	4xM16	9	180
125	5"	10	8	4xM16	9	210
150	6"	10	8	4XM20	10	240
200	8"	10	8	4XM20	12	295
250	10"	10	12	8XM20	12	350
300	12"	7	12	8XM20	19	400
350	14"	7	16	10XM20	20	460
400	16"	7	16	10XM24	24	515
450	18"	7	20	14XM24	24	565
500	20"	4	20	14XM24	24	620
600	24"	4	20	14XM27	24	725
700	28"	2	24	16XM27	29	840
800	32"	2	24	16XM30	29	950
900	36"	2	28	20XM30	40	1050
1000	40"	2	28	20XM33	40	1160
1200	48"	2	32	24XM36	40	1380

n- total number of holes
n₁- number of threaded holes



7175 RVS meskantafsluiter pneumatisch DW

WORKING CONDITIONS

Maximum working pressure : DN50-250 : 10 bar
 DN 300-450 : 7 bar
 DN500-600 : 4 bar
 DN700-1200 : 2 bar

Maximum working temperature : -10°C / +130°C (EPDM Joint in standard)

⚠ The above mentioned pressures are only valid if the direction of assembly indicated by the arrow on the valves is observed.

Upstream/downstream tightness

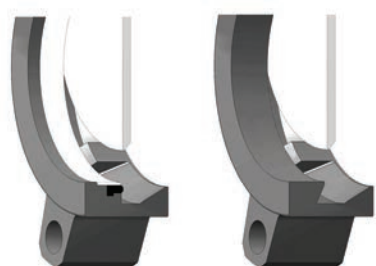

Elastomer tightness

Metal/metal tightness

Packing tightness

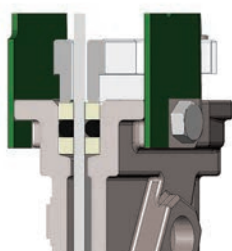

PTFE/Elastomer

Tightness in option

Tightness	Maximum temperature
Metal/metal	Tmax : -10°C / +80°C
NBR	Tmax : -10°C / +80°C
White EPDM	Tmax : -10°C / +130°C
Silicone	Tmax : -10°C / +170°C
FPM (Type Viton®)	Tmax : -10°C / +170°C
PTFE	Tmax : +4°C / +170°C
CSM (Type Hypalon®)	Tmax : +4°C / +80°C

⚠ To ensure a satisfactory tightness, when using the PTFE gasket, the operating pressure must be at least 1 bar.

FLOWS

Kv of valves (m³/h)

DN		Operating stroke, %									
mm	inch	10%	20%	30%	40%	50%	60%	70%	80%	90%	100%
50	2"	1,41	7,57	18,4	33,27	52,61	74,78	98,45	120,81	149,53	161,66
65	2 1/2"	2,41	8,58	25,4	49,32	85,77	121,51	167,85	219,67	287,45	317,77
80	3"	3	13,1	46,66	79,57	122,11	199,58	276,85	359,84	432,49	461,98
100	4"	3,86	33,06	75,62	125,01	206,17	311,72	474,43	681,36	865,17	993,21
125	5"	19,64	47,05	107,47	177,8	295,95	444,71	675,13	973,05	1231,14	1385,15
150	6"	28,88	104,25	181,37	281,61	418,76	614,83	884,79	1177,11	1482,44	1613,77
200	8"	24,04	141,73	251,71	418,72	514,76	785,11	1227,16	1982,56	2491,22	2783,27
250	10"	115,44	367,52	693,84	1141,65	1634,09	2342,79	3243,71	3960,67	5336,19	5951,8
300	12"	103,12	535,87	1023,55	1619,5	2441,26	3508,29	4553,83	6339,29	7862,36	8373,88
350	14"	218,4	725,8	1323	2173,2	3294,8	4914,3	7120,9	11415,3	19105,4	24890,7
400	16"	389,1	1150,1	2024,4	3130,9	4669,6	7009,1	10355,2	16014,2	22600,5	26497,7
450	18"	402,7	1287,3	2402,9	3803,4	5686,8	8247,3	12248,7	17298,5	26403,9	29485
500	20"	617	1611,1	2935,9	4625,8	7054,7	10438,9	15446	23582,8	35107,4	42784

